

HDDJETNOZZLE.COM

NO	REQD	MATERIAL	SH
1.	1	STL TBG C-1026 ASTM A513-5	
2.	1	AISI 1045 Medium Carbon Steel	
3	1	SSTL 316 STAINLESS STEEL	

Notice of DISCLAIMER

Notice to the Corporation, Person &/or Persons regarding the Computer Aided Design and Drafting (CADD) files &/or printed design drawings enclosed. Acceptance of the CADD data, &/or printed design drawings is based on the following disclaimer which covers all CADD data &/or printed design drawings received from the Cherrington LLC and/or William Cherrington.

The Cherrington LLC and/or William Cherrington makes no representation or warranties, express or implied, with respect to the reuse of the data provided herewith, regardless of its format or the means of its transmission. There is no guarantee or representation to the user as to the accuracy, currency, suitability or reliability of this data for any purpose. The user accepts the data &/or printed design drawings "as is", and assumes all risks associated with its use. By acceptance of this data &/or printed design drawings, the user agrees not to transmit this data or provide access or any part of it to another party unless the user shall include with the data a copy of this disclaimer. The Cherrington LLC and/or William Cherrington assumes no responsibility for actual or consequential damage incurred as a result of any user's reliance on this data &/or printed design drawings.

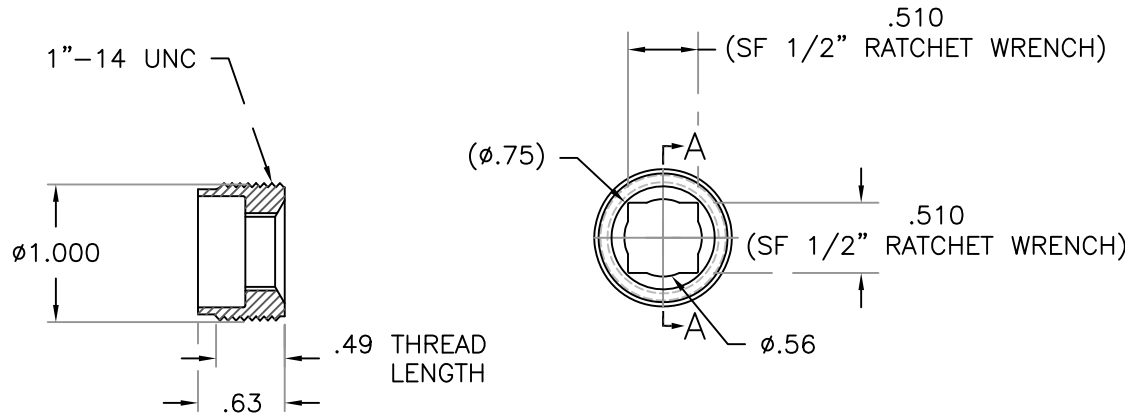

SECTION A-A

NOTES MATERIAL FINISH:

- NO. 1, 2 APPLY HOT BLACK OXIDE FINISH PER ASM 2485 WITH A HOT OIL FINISH AND RINSE TO MATERIAL
- NO. 3 NATURAL FINISH (NO FINISH) REMOVE BURRS. SHARP EDGES

Copyright © 2014 Cherrington LLC All Rights Reserved Notification of Proprietary Design & Data This material embodies confidential or proprietary information which is the property of Cherrington LLC of Cheyenne, Wyoming, USA and which shall not be produced in any manner, stored in any databank or retrieval system, disclosed to others were used in whole or in part to copy and reproduce the reference part without express written consent of the property owner as referenced.

REV	DATE	REVISION DESCRIPTION	BY	CHK'D	APP.
A	2/6/14	ADDED C'SINK, REV -1 MATL & NOTE 1.	RJC	RJC	

HDDJETNOZZLE General Dimensions Public Distribution	NOZZLE RETAINER 65 SERIES		
DATE: 6FEB14	DRAWN BY: RJC	CHKD BY:	APPRVD BY:
UNLESS OTHERWISE SPECIFIED DIMENSIONS ARE IN INCHES. TOLERANCES ARE: .X ± .020 .X ± .015 .XX ± .010 ANGLES ±1° .XXX ± .003 FRACTIONS ±1/16	REVISION: A	SCALE: 1/1	SHEET: 1 OF 1
	JOB NO.	FILE NAME: 5710-0100-1C	
	DWG NO. PD-5710-0100-1C		